

SERVICE BULLETIN NO. MSB1078-169

I. TECHNICAL DETAILS

1.1 Category:

Mandatory

1.2 Airplanes affected:

Bezeichnung / Description	LBA Kennblatt-Nr. TCDS	EASA TCDS	FAA TCDS	Serial-Nr.
G 115C	1078	EASA.A.364	A57EU	82001-82084 (C)
G 115C2	1078	EASA.A.364	A57EU	82001-82084 (C2)
G 115D	1078	EASA.A.364	A57EU	82001-82084 (D)
G 115D2	1078	EASA.A.364	A57EU	82001-82084 (D2)
G 115E	1078	EASA.A.364		82086/E-82185/E 82301/E-82323/E
G 115EG	1078	EASA.A.364	A57EU	82200-82273

1.3 Time of Compliance:

During next 100 hours inspection

1.4 Subject:

ATA-Code: 52-10 Canopy
Inspection of the canopy lock

1.5 Reason:

Grob received a report where at several aircraft the locking nut (see Fig. 1) of the canopy lock was found loose or missing. Therefore also the toothed washer and the locking lever detached from the barrel-lock. This Service mandates a one-time inspection for tight fit and the securing of the locking nut using Loctite.

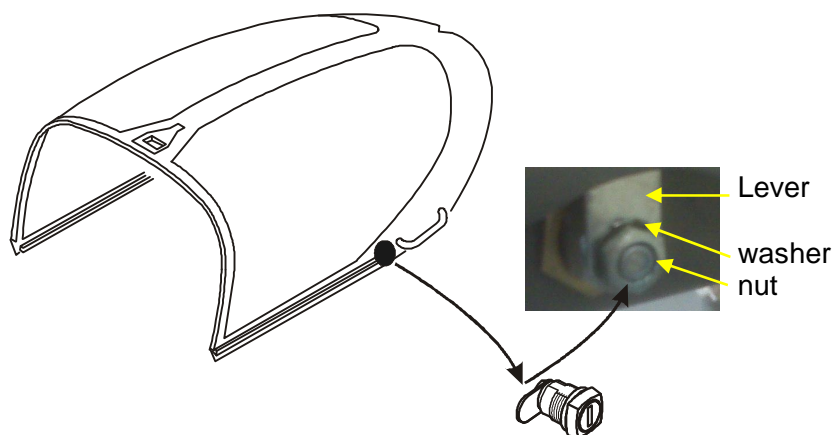

1.6 Concurrent documents:

N/A

1.7 Approval Note:

The technical content of this document is approved under the authority of EASA Design Organization Approval No. EASA.21J.030.

1.8 Accomplishment/ Instructions

- 1.8.1 Ensure that the aircraft is safe for parking I.A.W. MM chapter 10-10.
- 1.8.2 Move the canopy full aft.
- 1.8.3 Check large nut attaching the lock (Fig. 2, item 18) and the small nut attaching the lever to the barrel for tight fit.

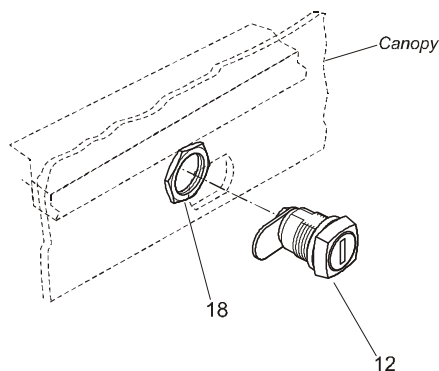

Fig. 2

- 1.8.4 Loose nuts shall be secured using Loctite 243 (GS GROB-513007). Replace missing or defective parts.
- 1.8.5 Release aircraft back to service.

1.9 Repetitive Actions

N/A

II. PLANNING INFORMATION

2.1 Weight and CG

N/A

2.2 Material and Availability

Item	Part Number	Description	Quantity	Remarks
1	GS-GROB-513007	Loctite 243	AR	

Further required parts may be ordered according to the corresponding IPC.

2.2 Special Tools

N/A

2.3 Labor costs

N/A

2.4 Reference documents

G 115C/D AMM
G 115E AMM
G 115EG AMM

2.5 Credit

N/A

III. REMARKS

- The correct execution of the instructions in paragraph 1.8 may be performed by a competent person/an authorized aviation workshop or at the manufacturer and has to be certified in the logbook by an authorized inspector.
- If you have sold your aircraft in the meantime, would you kindly pass this information on to the new owner and forward his address and aircraft S/N to us.
- For questions and assistance please contact:

Rudi Vodermeier, Head of Customer Service & Support,

phone: +49 8268 998139

fax: +49 8268 998200

e-mail: productsupport@grob-aircraft.de

SB-Index: <http://www.grob-aircraft.eu/service-and-support/g-115.html>

Order: <http://www.grob-aircraft.eu/service-and-support/general/order-form.html>