

This Service Bulletin substitutes the Service Bulletin TM 817-34, dated 14 January 1992.

Subject: Inspection of the BENDIX-magnetos at the GROB 2500 engine

Concerning: G 109B, as of S/N 6200

Urgency: first within the next 25 flight hours, then every 100 hours inspection

Procedure: During engine inspections too less clearance between flyweights and stop pin has been found.

Action: To prevent a possible damage of the magnetos or the engine, inspections for the clearance between flyweights and stop pin are required. Perform as follows:

I. Clearance flyweight and stop pin (measured at the heel)

Caution: - Ignition switch "OFF"
- Disconnect ignition harness from all spark plugs. Ground ignition leads to avoid sparking.
- Remove all spark plugs.

1. Remove magneto(s).

2. Measure the clearance between stop pin and flyweights with a proper measuring instrument as follows:

Note: At engines with dual ignition, both magnetos must be checked.

a. Pull the flyweight outwards by using a proper tool (for example a stiff, bended wire), measure the clearance and note the value. The clearance must have a minimum of 0,43 mm (=0,017 inch).

b. Repeat the measurement for the second flyweight.

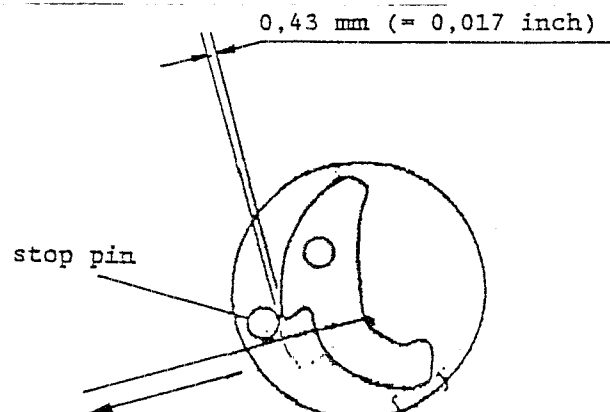

Warning: If the clearance is less than 0,43 mm (=0,017 inch), further operation of the engine with this magneto is not allowed, and the manufacturer must be contacted immediately.

- c. Connect ignition harness.
- d. If the clearance is sufficient, install the magneto(s) and adjust the ignition timing, according to the Operations Manual GROB 2500.
- e. Install spark plugs.
- f. The measured clearance of each flyweight, the flight hours and the operating hours of the magneto(s), must be reported to the manufacturer with the attached form.

II. Checking the axle wear of riveted flyweights according to Service Bulletin No. 599D "Inspection of riveted Impulse Couplings and Stop Pins", dated January 1992 (refer to Appendix)

Material: Material can be obtained from the manufacturer if necessary.

Weight and Balance: not effected

- Remarks:**
1. The inspection must be carried out in an authorized aviation work shop and certified in the log book by an authorized inspector.
 2. If in the meanwhile you have sold your motor-glider, we would ask that you kindly pass this information directly to the new owner and forward his address and aircraft s/n to us.

Mattsies, 17 March 1992

LBA approved

The German original of this service bulletin has been approved by the LBA on the 19.03.1992 and is signed by Mr. U. Kopp. The translation has been accomplished to our best knowledge and judgement. In case of doubt, the German original is authoritative.

R. Rischer
Dipl.Ing. R. Rischer
(Airworthiness engineer
certification staff)

Appendix: Service Bulletin No. 599D (6 pages)

DATUM / DATE 17 March 1992	ERSETZT AUSGABE / ISSUE EDITION 14 Jan. 1992	BEARBEITET / PREPARED BY R. Vodermeier	MUSTERGEPRÜFT / APPROVED BY	SEITE / PAGE 2 of 2
-------------------------------	---	---	-----------------------------	------------------------