

THIS SERVICE BULLETIN SUBSTITUTES TM 1078-12 DATED 27 JUNE 1990

Subject: Cracks on main landing gear axles

Concerning: GROB G 115 / G 115A all s/n's

Urgency: Action 1 before next take-off
Action 2 before next take-off, or 31st Dec.
1990 latest

Procedure: To achieve the correct 90° angle between the main landing gear axle and the attachment plate (drawing no. 109-5016), it was in some cases necessary to machine the plate. During this machining process the welded seam was slightly removed and this could lead to a "notch" effect resulting in cracks at a later stage especially if the G 115 is operated from grass or un-even runway facilities.
The danger of cracking also exists on non machined axles, if during extremely hard landings overloads arise in the welding seam.
As a **precautionary measure** a check should be carried out and in the course of action 2 a modified version of the axles installed.

Actions:

1. Check for cracks on axles

The axles must be checked by colour penetration procedures for cracks.

- a) If any cracking is either found or suspected: immediate implementation of action 2 should be carried out.
- b) If no evidence of cracks is observed: further checks must be performed after each 500 take-off until action 2 is implemented.

2. Exchange of axles

The axles have to be exchanged according to the Installation Instruction belonging to Service Bulletin TM 1078-12/1.

Note:

It is the owners responsibility that after any special occurrence (i.e. after hard landing) an inspection has to take place, even if the airplane has not performed 500 take-offs.

Material:

The material (incl. Installation Instruction) may be obtained directly from the manufacturer free of charge by means of the enclosed order form.

Weight and Balance: negligible

Remarks: Actions 1 and 2 are to be carried out by a competent person or an authorized aviation workshop and the correct installation has to be certified in the logbook by an authorized inspector.

Mattsies, 04 July 1990

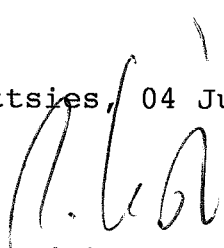
signed i.A. R. Rischer
(Airworthiness engineer
certification staff)

LBA-approved:

10.7.1990

Note: If in the meantime you have sold your aircraft, we would ask that you kindly pass this information immediately to the new owner and forward his address and aircraft s/n to us.

This installation instruction no. 1078-12/1 is issued against the Service Bulletin TM 1078-12/1 and contains instructions for carrying out action no. 2 (exchange of axles).

If, when carrying out action no. 1:

- a) cracks are found, carry out work steps I and II
- b) no cracks are found, the axle can continue in service and only work step II need be carried out.

Materials: for work step I: 1 or 2* axles 109-5016
for work step II: 2 QTY plates 115-5010
2 QTY close tolerance steel rings 115-5011

* depending on how many cracked axles are found

Tools: Normal tool kit

I. Installation of new landing gear axle

Remove and install landing gear axle in accordance with G 115 Maintenance Manual, chapter 32-10, pages 1 through 4. During removal and installation, carefully note the quantity and location of the adjustment washers, otherwise the track will have to be re-adjusted.

If track adjustment is necessary, proceed as described in the G 115 Maintenance Manual, chapter 32-10, page 5.

II. Modification of axle attachment

1. Clean the removed landing gear axle.
2. Grease landing gear axle.
3. Measure dimension X of brake caliper and of close tolerance steel ring 115-5011.

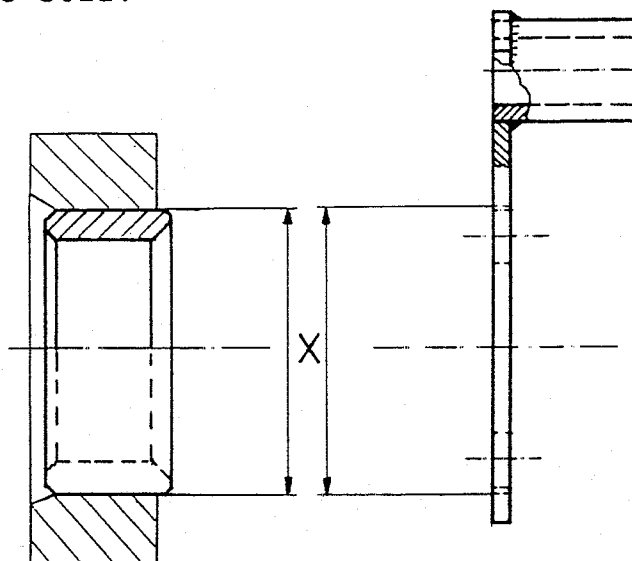

4. If there is a difference between the dimensions of the two components or, if they cannot be assembled, carry out step 5.

5. Grind brake caliper lightly to dimension X using a cylinder grinder; ensure fit is free of play.
6. Apply grease to bore of brake caliper for corrosion protection.
7. Install plate 115-5010 with interference fit close tolerance ring on to landing gear axle.
8. Install brake caliper on to landing gear axle.
9. Bolt landing gear axle to main landing gear using four M8 x 55 bolts. Torque bolts to 16 Nm.
10. Carry out the remaining work steps in accordance with G 115 Maintenance Manual (see paragraph I).

This modification must be checked and signed off in the logbook by an authorized inspector.

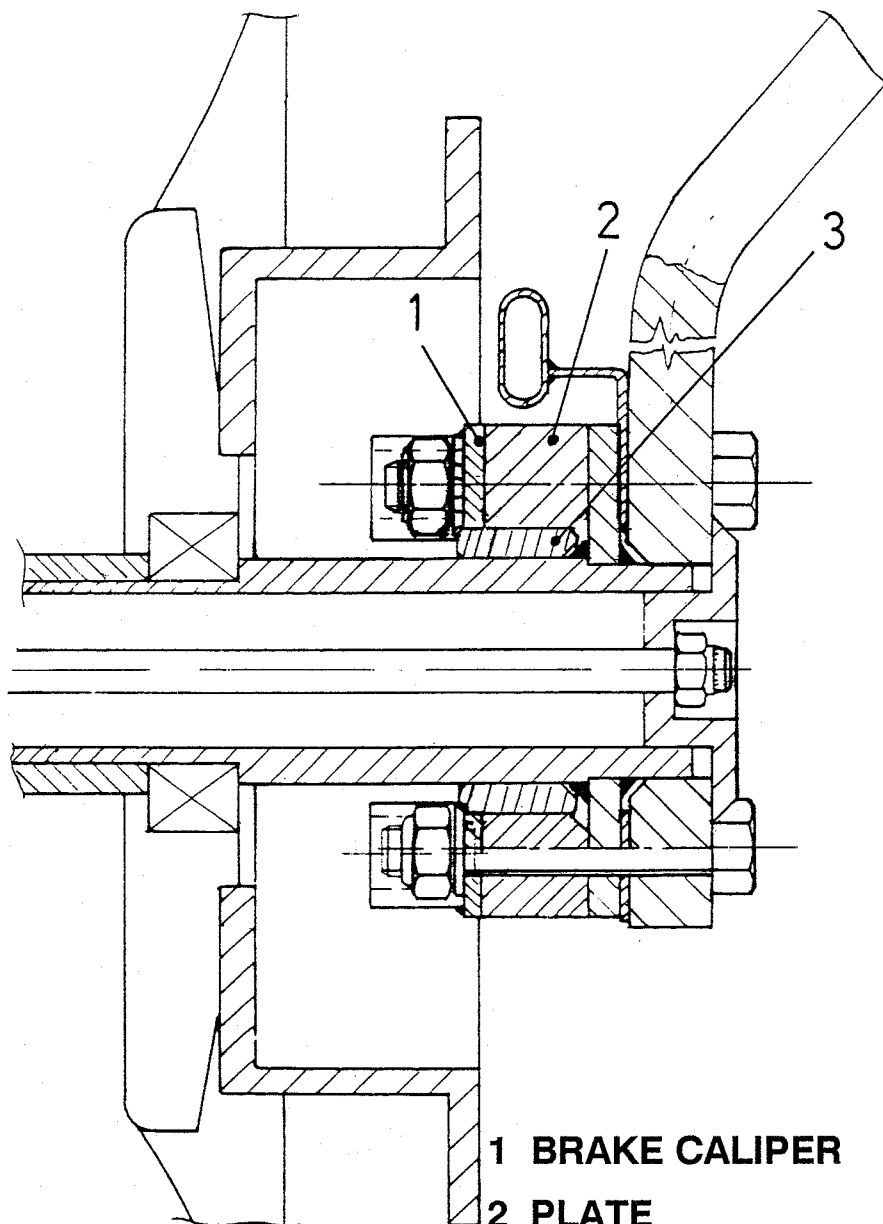

1 BRAKE CALIPER

109-5117

2 PLATE

115-5010

3 CLOSE TOLERANCE STEEL RING 115-5011